



FRP Enclosures Sunshades Kiosks & Shelters



First Reinforced Polyester Industries LLC



First Reinforced Polyester Industries LLC (FRP Industries) is a customer oriented **Fiberglass Reinforced Polyester (FRP)** composite specialist having its manufacturing base in new industrial area, Umm Al Quwain, United Arab Emirates. **FRP Industries** is an **ISO 9001:2015 certified company** from Quality Registrar Systems (QRS).

The organization's management understands the market needs from a visionary perspective and consistently evolves its product portfolios with utmost value proposition.

- Evolved by a visionary technocrat with more than a decade of incomparable experience in the composite industry.
- An organization which has time and mind to understand client needs while designing products.
- A team of handpicked workforce with high commitment and adaptability for ever changing demands.
- An organization which believes in quality consistency.
- A team which challenges the set standards consistently.
- An organization which provides cost effective and quality solutions to clients.

FRP Industries provides a wide range of products for various applications. Our product range is:

- Enclosures for Electrical Switchboard & Feeder Pillars
- Enclosures for Utility Meters (Electricity/Water/Gas)
- Enclosures for Batteries & Solar Combiner Box (SCB)
- Instruments Enclosures & Sunshades
- Junction & Marshalling Box
- Kiosk/Large Housing for Package Substation, MCC & Capacitor Bank
- Shelters for Analyzers
- Fire & Safety Cabinets

Within a short span of inception, FRP Industries has proven its capabilities by expanding its product range by catering to the needs of the construction, engineering, infrastructure, power and industrial sectors.

Continuous patronage through repeat orders from the satisfied clients across the market and industry segments holds the testimony for FRP Industries operational excellence.

FRP Industries products are weatherproof and designed to protect any type of electrical, electronic, instrumentation and other types of industrial equipment from all kind of weather in outdoor installation. These FRP products are UV resistant, corrosion resistant, fire resistant and suitable for outdoor use in harsh weather conditions of high humidity and temperature dominant Gulf region. Our FRP products are manufactured by high quality polyester gelcoats, resin and E-glass fiber. Our manufacturing process maintain a protective layer of 400-500 microns gelcoat against weathering by UV radiation and humidity. Our FRP products have design life in excess of 40 years.

Advantages of FRP as material

Composite products made of FRP (Fiberglass Reinforced Polyester/GRP/FGRP) are classified as the modern-day material, owing to its superiority in terms of its adjustable characteristics such as high strength-to-weight ratio, commendable thermo-mechanical, non-conductive and corrosion resistant properties.

- FRP is light-weight and helps in cutting expenses on labor and installation. FRP increases construction speed that further reduces environmental impacts.
- FRP materials are not just durable; they also have high strength as compared to traditional materials. Users can expect less material usage to attain better or similar performance compared to conventional materials which result in lessened resource use as well as waste production.
- FRP has great potential in further maximizing the longevity of existing as well as new and structures that can resist the harsh effects of weathering, degradation, and aging in severe environments.
- FRP materials are extremely resistant to corrosion and rot. Besides these, they present a longer and yet more efficient service life. FRP products hardly require an energy-intensive placement and are almost maintenance free.

FRP Electrical Enclosures

FRP enclosures are designed to protect mainly LV switchgears, utility meters and other electrical components from all kind of weather in outdoor installation. These enclosures are generally suitable for installation on flat concrete floor, however there is an option to mount on wall or pole. These enclosures are UV resistant, corrosion resistant, fire resistance and precisely suitable for outdoor use in harsh weather conditions of high humidity and temperature dominant in gulf region. These enclosures have design life in excess of 40 years.

► Standard Features

- Ingress protection to IP66, IP65, IP55 & lesser (Certified to BS EN 60529)
- Weatherproof and UV resistant (Certified to ASTM G154)
- Fire retardant & self-extinguishing (Certified to BS476 Part 7 Class 2)
- High impact resistant up to IK10 (Certified to BS EN 62262)
- Anti-static (Certified to IEC 60079-0)
- Standard external finish: Semi-gloss UV resistant grey color gelcoat finish to RAL7035
- High temperature resistant & long-life EPDM rubber gasket for door sealing
- Molded threaded studs on back wall for mounting plate fixing
- All hardware of galvanized steel or corrosion resistant material



Model: FEM Series



Model: FES Series



Model: FED Series



Model: FJB Series

► Options

- Ingress protection to NEMA 4X and lesser (Certified to NEMA250)
- Higher fire rating (Certified to BS476 Part 7 Class 1/UL94 V-0)
- Insulated construction sandwich with PU foam/Rockwool.
- Anti-vandal construction sandwich with WBP plywood.
- Additional Inner door
- Stainless steel hardware
- External colors in any other RAL color.

► Accessories

- Mounting Plate
- Gland Plate
- UV Resistant See-through Window
- Plinth/Pedestal
- Vents (Natural/Forced)*
- Lifting Hooks
- Wind Stays
- Document Pocket
- Wall Mounting Brackets

*Adding vents may reduce ingress protection

FRP Electrical Enclosures

Model: FEM Series (Single Door Enclosure)

- Wall thickness 3mm commonly & 5mm at stress points
- Single door
- Awning rain canopy
- Quarter turn square key lock, chrome plated zinc die cast
- Liftoff Hinges, chrome plated zinc die cast
- Customizable with different accessories & dimensions



All dimensions are in mm

S No.	Model Number	Internal Size			Clear Access		Mounting Plate Size		Gland Cutout Size		C-C of studs		C-C of Wall Brackets		C-C of Foundation	
		h	w	d	Height	Width	Height	Width	J	K	A	C	F	G	L	M
1	FEM030020015*	300	200	150	240	140	250	170	120	60	210	x	195	230	100	70
2	FEM039029019*	390	290	190	330	230	340	250	180	80	300	210	335	335	190	140
3	FEM045030018*	450	300	180	390	240	400	250	200	80	360	210	345	345	200	130
4	FEM045040020	450	400	200	340	290	340	340	300	80	300	300	345	445	300	150
5	FEM050050030	500	500	300	390	390	390	440	350	120	350	400	395	545	400	250
6	FEM060040020	600	400	200	490	290	490	350	300	80	450	310	495	445	300	150
7	FEM060050020	600	500	200	490	390	490	430	350	80	450	390	495	545	400	150
8	FEM065055021	650	550	210	540	440	530	470	400	80	490	430	545	595	450	160
9	FEM070055025	700	550	250	590	440	530	470	400	120	490	430	595	595	450	200
10	FEM080060020	800	600	200	690	490	690	520	400	80	650	480	695	645	500	150
11	FEM085060020	850	600	200	740	490	740	520	400	80	700	480	745	645	500	150
12	FEM085080030	850	800	300	740	690	740	720	600	120	700	680	745	845	700	250

*Without canopy & with butt hinges

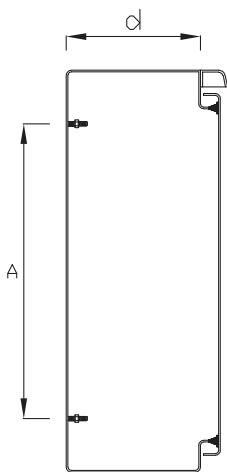

SECTION Y-Y

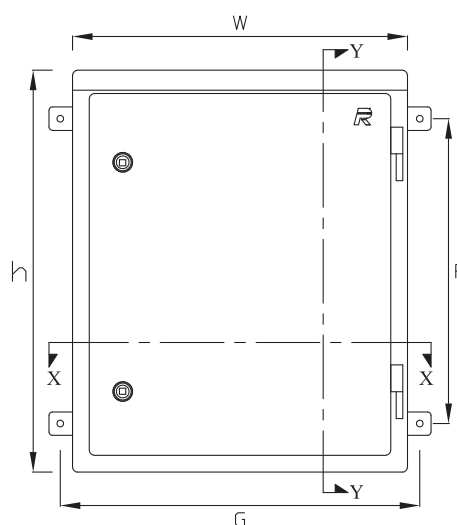

FRONT ELEVATION

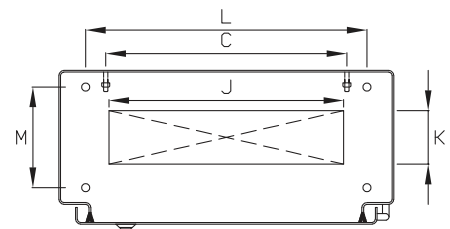

SECTION X-X

FRP Electrical Enclosures

Model: FES Series (Single Door Enclosure)

- Wall thickness 4mm commonly & 6mm at stress points
- Single door
- Full rain canopy
- Quarter turn square key lock, chrome plated zinc die cast
- Liftoff Hinges, chrome plated zinc die cast
- Customizable with different accessories & dimensions



All dimensions are in mm

S No.	Model Number	Internal Size			Clear Access		Mounting Plate Size		Gland Cutout Size		C-C of studs			C-C of Wall Brackets			C-C of Foundation	
		h	w	d	Height	Width	Height	Width	J	K	A	B	C	F	I	G	L	M
1	FES100060030	1000	600	300	890	490	840	520	400	150	800	x	480	890	x	70	500	250
2	FES100080025	1000	800	250	890	690	840	720	600	120	800	x	680	890	x	140	700	200
3	FES100080030	1000	800	300	890	690	840	720	600	150	800	x	680	890	x	130	700	250
4	FES120085030	1200	850	300	1090	740	1040	720	600	150	x	500	680	x	545	150	750	250
5	FES130080040	1300	800	400	1190	690	1220	720	600	200	x	590	680	x	595	250	700	300
6	FES140080030	1400	800	300	1290	690	1220	720	600	150	x	590	680	x	645	150	700	250
7	FES160090040	1600	900	400	1490	790	1400	790	700	200	x	680	750	x	745	150	800	350
8	FES200080060	2000	800	600	1890	690	1870	720	600	200	x	915	680	x	945	160	700	550

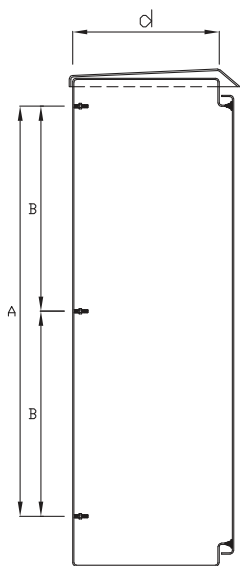

SECTION Y-Y

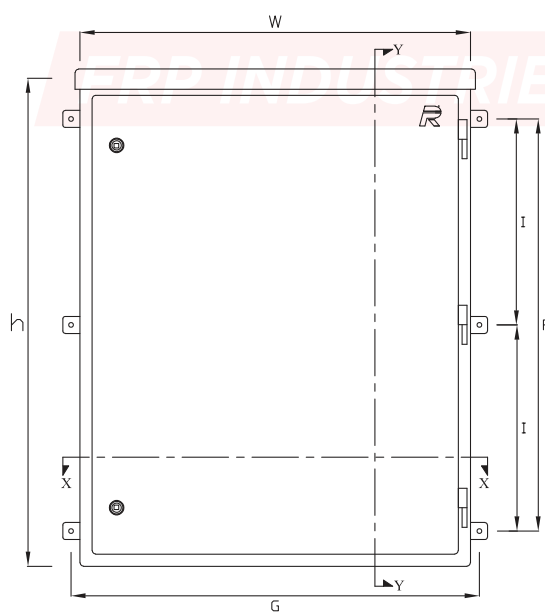

FRONT ELEVATION

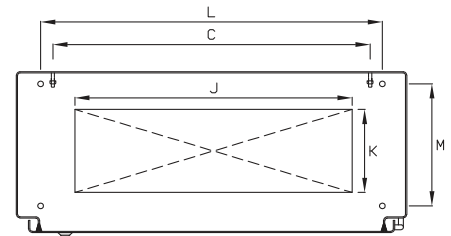

SECTION X-X

FRP Electrical Enclosures

Model: FED Series (Double Door Enclosure)

- Wall thickness 4mm commonly & 6mm at stress points
- Double door
- Full rain canopy
- Handle lock with 3 point locking
- Lifting Hinges, chrome plated zinc die cast
- Customizable with different accessories & dimensions



All dimensions are in mm

S No.	Model Number	Internal Size			Clear Access		Mounting Plate Size		Gland Cutout Size		C-C of studs			C-C of Wall Brackets		C-C of Foundation		
		h	w	d	Height	Width	Height	Width	J	K	B	C	E	I	G	L	N	M
1	FED120100030	1200	1000	300	1090	890	1040	890	800	150	500	850	x	545	1070	900	x	250
2	FED120100040	1200	1000	400	1090	890	1040	890	800	200	500	850	x	545	1070	900	x	350
3	FED140100040	1400	1000	400	1290	890	1220	920	800	200	590	880	x	645	1070	900	x	350
4	FED140120040	1400	1200	400	1290	1090	1220	1120	400(2)	200	590	x	540	645	1270	x	550	350
5	FED160120040	1600	1200	400	1490	1090	1400	1120	400(2)	200	680	x	540	745	1270	x	550	350
6	FED160140050	1600	1400	500	1490	1290	1400	1220	500(2)	230	680	x	590	745	1470	x	650	450
7	FED180120040	1800	1200	400	1690	1090	1640	1120	400(2)	200	800	x	540	845	1270	x	550	350
8	FED210140060	2150	1400	600	2040	1290	1990	1220	500(2)	230	975	x	590	1020	1470	x	650	550

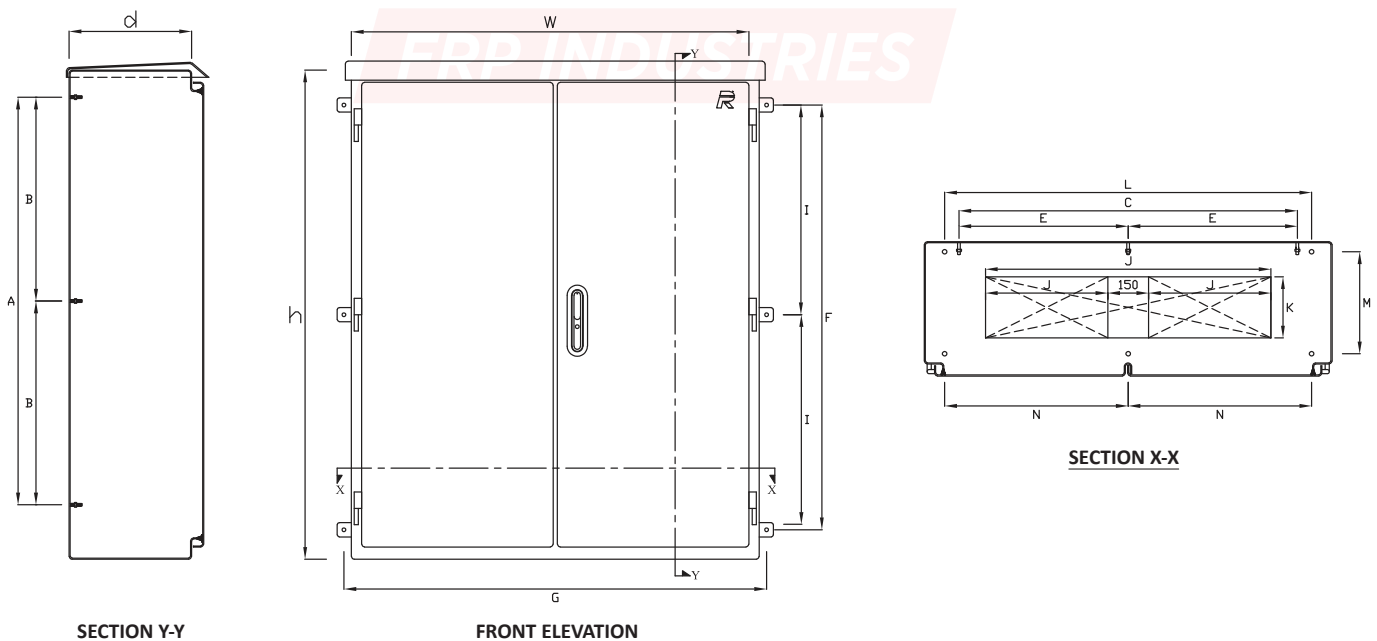

FRP Electrical Enclosures



Model: FJB Series (Junction Box)

- Bolted cover type
- Wall thickness 3mm commonly & 5mm at stress points
- Ingress protection to IP66
- Option to fix DIN rail/terminals on back wall.
- Customizable with different accessories & dimensions

All dimensions are in mm

S No.	Model Number	Internal Size		
		h	w	d
1	FJB140140100	140	140	100
2	FJB190190130	190	190	130
3	FJB300200120	300	200	120
4	FJB350300200	350	300	200
5	FJB450300200	450	300	200
6	FJB600600200	600	600	200

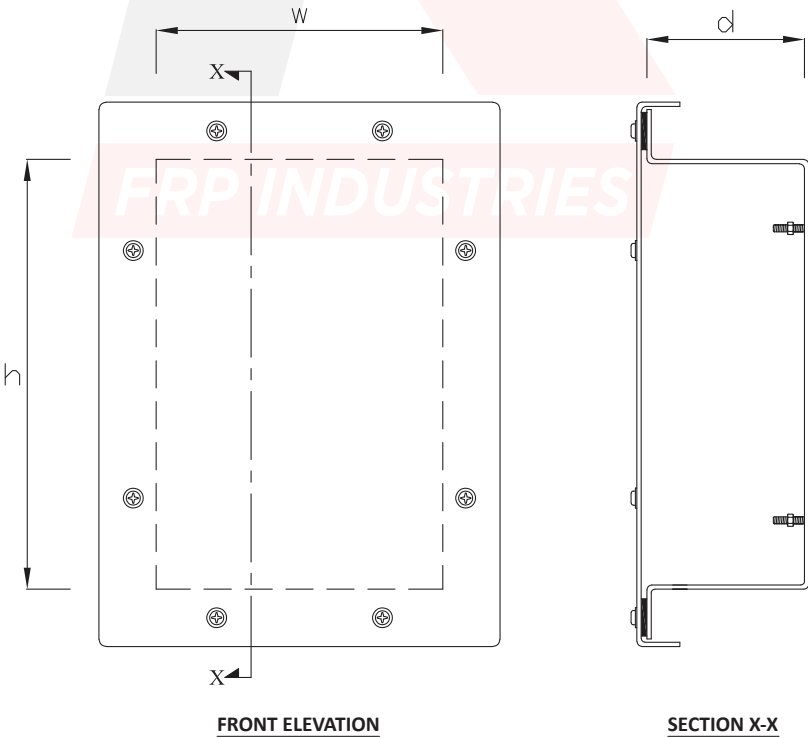

Disclaimer: FRP Industries reserves the right to amend the design shown in this document without prior notice

FRP Battery Enclosures

FRP battery enclosures are designed to protect industrial grade batteries and UPS systems from all kind of weather in outdoor installation for off-grid/on-grid applications. These battery enclosures are generally suitable for installation on flat concrete floor or metallic frame/skid, however it can be designed for underground installation or pole mounting. There are options for heavy duty FRP rack to achieve multiple battery steps within enclosure. These battery enclosures are UV resistant, corrosion resistant, fire resistance and precisely suitable for outdoor use in harsh weather conditions of high humidity and temperature dominant in gulf region. These battery enclosures have design life in excess of 40 years.

► Standard Features

- Ingress protection to IP65, IP55, IP54 & lesser (Certified to BS EN 60529)
- Weatherproof and UV resistant (Certified to ASTM G154)
- Fire retardant & self-extinguishing (Certified to BS476 Part 7 Class 2)
- Impact resistant up to IK10 (Certified to BS EN 62262)
- Anti-static (Certified to IEC 60079-0)
- Wall thickness 3mm to 6mm.
- Standard external finish: Semi-gloss UV resistant grey color gelcoat finish to RAL 7035.
- High temperature resistant & long-life EPDM rubber gasket for door sealing.
- All hardware of non-corrosive stainless steel.



Model: FBS Series

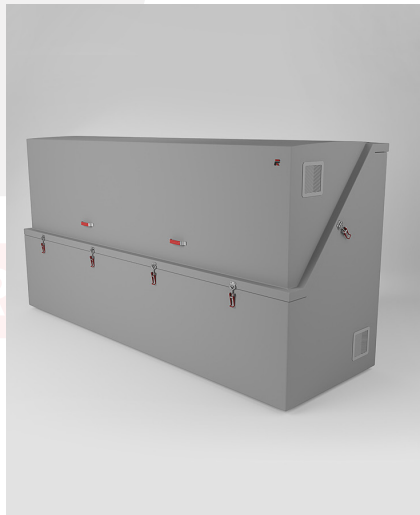

Model: FBH Series



Model: FBF Series

► Options

- Ingress protection to NEMA 4X and lesser (Certified to NEMA250)
- Higher fire rating (Certified to BS476 Part 7 Class 1/UL94 V-0)
- Higher wall thickness.
- Insulated construction sandwich with PU foam/Rockwool.
- Anti-vandal construction sandwich with WBP plywood.
- External colors in any other RAL color.
- Neoprene rubber gasket for better resistant to oil & solvent.
- Heavy duty FGRP rack to place batteries rows at different level.
- Tag plate/Name plate in traffolyte/PVC/stainless steel.

FRP Battery Enclosures

Model: FBS Series

- Economical standard design with removable top cover
- Easy locking by quick toggle latch
- Option of flat pack design for easy transport & handling

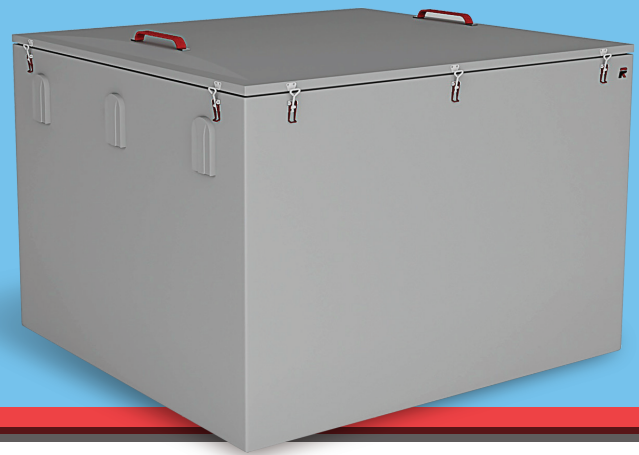

All dimensions are in mm

S.No.	Model Number	External Size			Clear Access	
		h	l	w	x	y
1	FBS040055040	400	550	400	490	340
2	FBS040080040	400	800	400	740	340
3	FBS065065060	650	650	600	590	540
4	FBS085125085	850	1250	850	1190	790
5	FBS085140120	850	1400	1200	1340	1140
6	FBS090150120	900	1500	1200	1440	1140

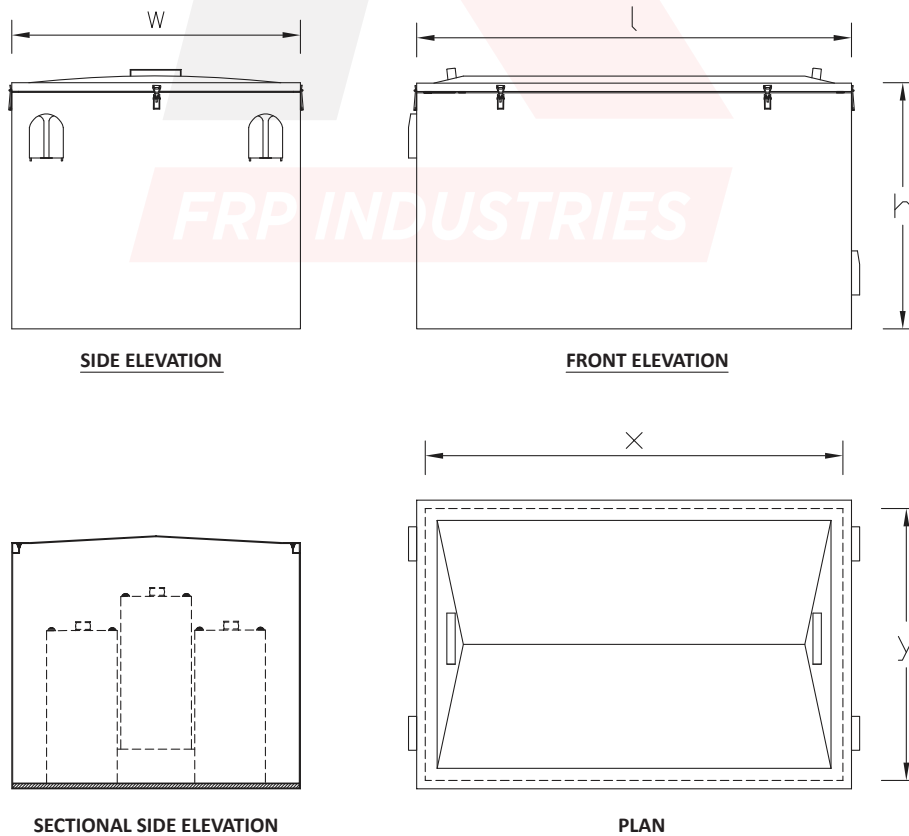

FRP Battery Enclosures

Model: FBH Series

- Slanting hinged cover for better visibility of batteries row
- Easy access & replacement of battery without any trouble to adjacent battery
- Easy locking by quick toggle latch

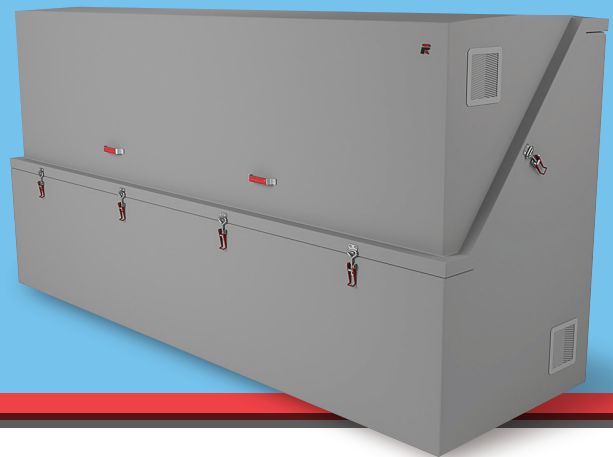

All dimensions are in mm

S.No.	Model Number	External Size			Clear Access	
		h	w	d	x	y
1	FBH095170085	950	1700	850	1575	750
2	FBH112225725	1125	2250	725	2125	625
3	FBH125150100	1250	1500	1000	1375	900

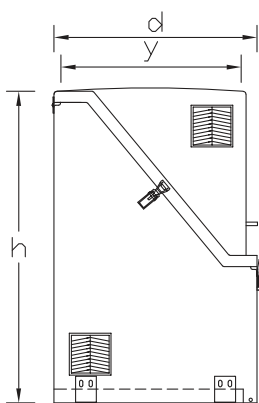

SIDE ELEVATION

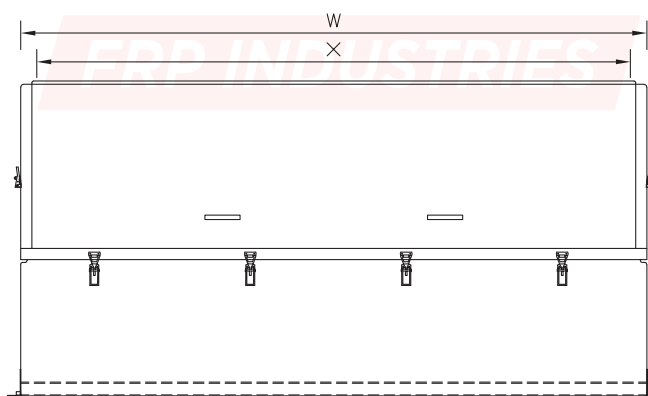

FRONT ELEVATION

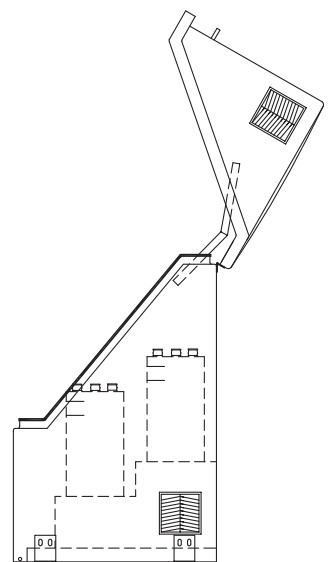

RIGHT SIDE ELEVATION WITH OPEN COVER

FRP Battery Enclosures

Model: FBF Series

- Lesser foot print, especially suitable for offshore application
- Removable hinged door
- Easy access & replacement of battery without any trouble to adjacent battery
- Choice to place batteries at multiple tier/step



All dimensions are in mm

S.No.	Model Number	External Size			Clear Access	
		h	w	d	x	y
1	FBF120085060	1400	850	600	1100	750
2	FBF210110060	2100	1100	600	1800	1000
3	FBF210135060	2100	1350	600	1800	1250

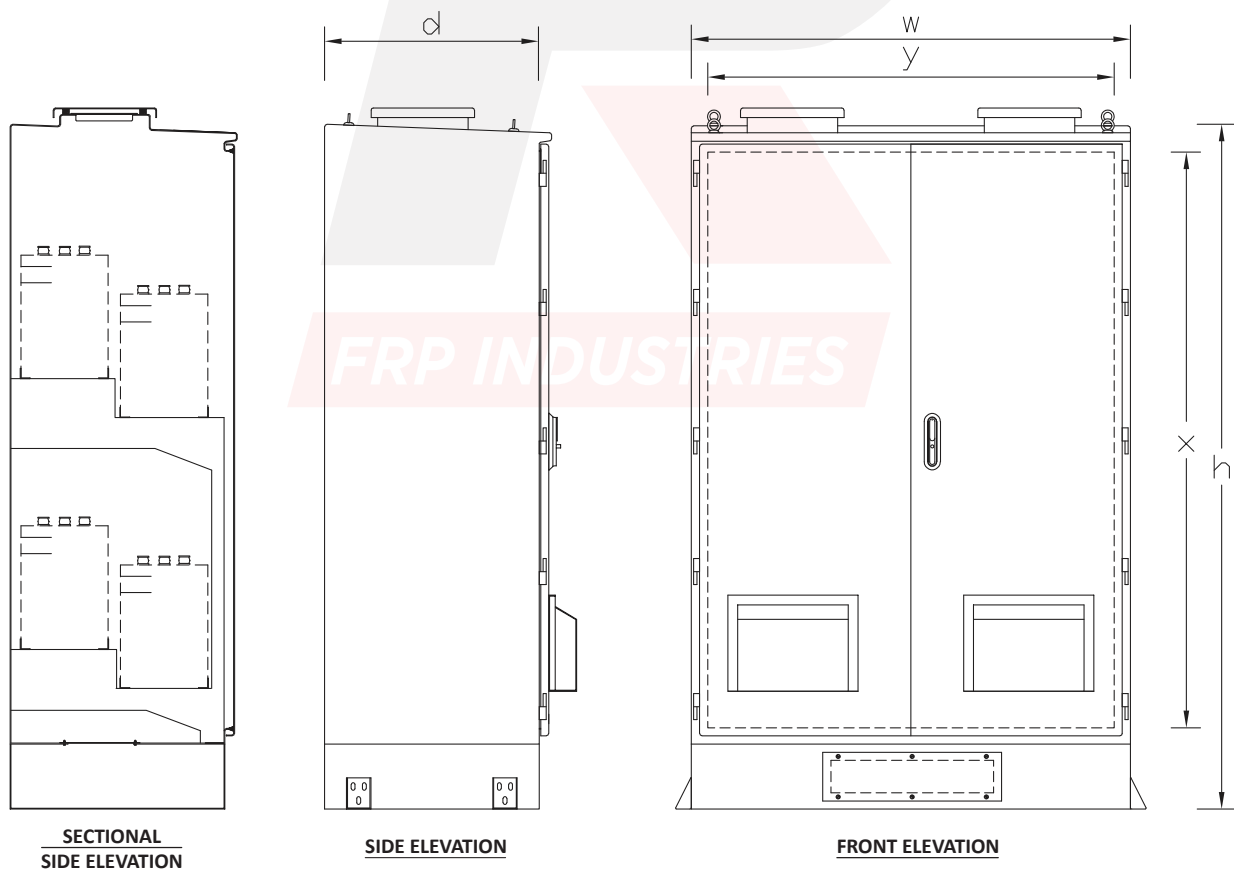

Disclaimer: FRP Industries reserves the right to amend the design shown in this document without prior notice

FRP Fire & Safety Cabinets

FRP fire & safety cabinets are designed to house fire extinguishers, fire hose reels, foam hydrant, lifebuoy and other safety equipment in outdoor application. These cabinets are precisely suitable for industrial use in process plant, refinery, petrochemical plant and marine application. These cabinets are suitable for installation on flat concrete floor, however there is an option to mount on wall or frame. These cabinets are fitted with locking system which can be unlocked easily without any key or tool during an emergency. These cabinets are UV resistant, corrosion resistant, fire resistance and precisely suitable for outdoor use in harsh weather conditions of high humidity and temperature dominant in gulf region. These cabinets have design life in excess of 40 years.

► Standard Features

- Ingress protection to IP66, IP65, IP55 & lesser (Certified to BS EN 60529)
- Weatherproof and UV resistant (Certified to ASTM G154)
- Fire retardant & self-extinguishing (Certified to BS476 Part 7 Class 2)
- High impact resistant up to IK10 (Certified to BS EN 62262)
- Anti-static (Certified to IEC 60079-0)
- Standard external finish: Semi-gloss UV resistant red color gelcoat finish to RAL 3000
- High temperature resistant & long-life EPDM rubber gasket for door sealing
- Base additionally reinforced to bear high load
- All hardware of galvanized steel or corrosion resistant material



► Options

- Ingress protection to NEMA 4X and lesser (Certified to NEMA250)
- Higher fire rating (Certified to BS476 Part 7 Class 1/UL94 V-0)
- Insulated construction sandwich with PU foam/Rockwool.
- Anti-vandal construction sandwich with WBP plywood.
- Stainless steel hardware
- External colors in any other RAL color.

► Accessories

- UV Resistant See-through Window
- Wall Mounting Brackets
- Plinth/Legs
- Vents

FRP Fire & Safety Cabinets



Model: FSC Series

- Wall thickness 3-4 mm generally
- Single door
- Awning rain canopy
- Polyamide wing lock
- Liftoff Hinges, chrome plated zinc die cast
- Customizable with different accessories & dimensions

All dimensions are in mm

S.No.	Model Number	Internal Size			Clear Access	
		h	w	d	x	y
1	FSC085030020	850	300	200	740	190
2	FSC085060020	850	600	200	740	490
3	FSC100030030	1000	400	300	890	290
4	FSC100080030	1000	800	300	890	690
5	FSC120100040	1200	1000	400	1090	890
6	FSC140100040	1400	1000	400	1290	890

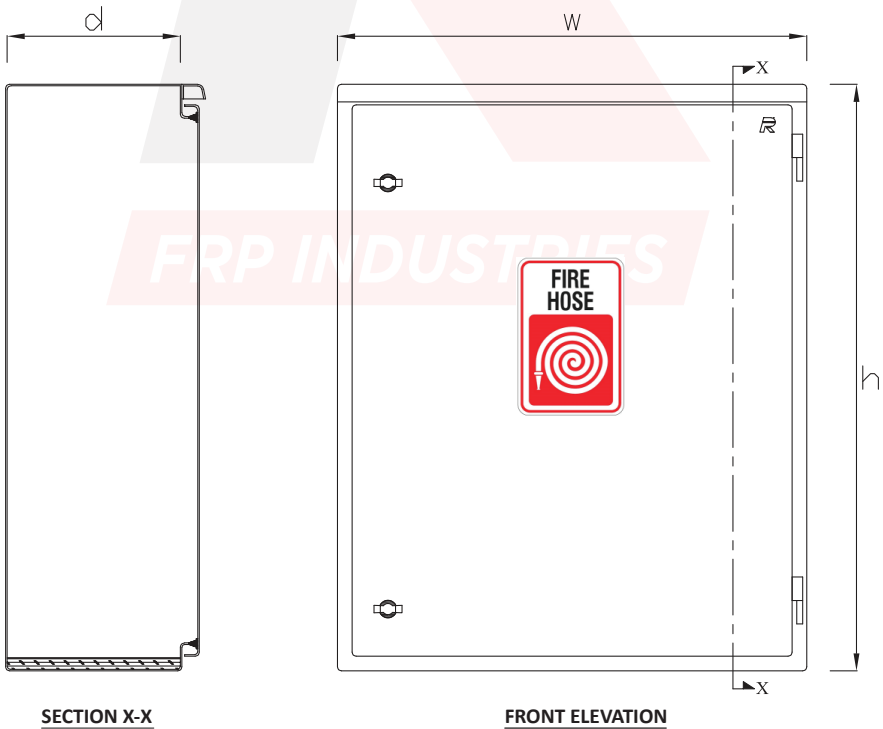

Disclaimer: FRP Industries reserves the right to amend the design shown in this document without prior notice

FRP Kiosks & Shelters

FRP kiosks & shelters are designed to house distribution transformers, MCC panels, LV panels, analyzers, capacitor banks, battery banks and other large electrical equipment in outdoor application. These kiosks & shelters are generally drop-over type suitable for installation on flat concrete floor, however it can be designed with heavy duty FRP or metal flooring. These kiosks & shelters are of modular design for easy transportation and on-site assembly/installation. These kiosks & shelters can be manufactured to suit project specific requirement. These kiosk & shelters are UV resistant, corrosion resistant, fire resistance and precisely suitable for outdoor use in harsh weather conditions of high humidity and temperature dominant in gulf region and have design life in excess of 40 years.

► Standard Features

- Ingress protection to IP55 & lesser (Certified to BS EN 60529)
- Weatherproof and UV resistant (Certified to ASTM G154)
- Fire retardant & self-extinguishing (Certified to BS476 Part 7 Class 2)
- High impact resistant up to IK10 (Certified to BS EN 62262)
- Anti-static (Certified to IEC 60079-0)
- Standard external finish: Semi-gloss UV resistant grey color gelcoat finish to RAL 7035
- High temperature resistant & long-life EPDM rubber gasket for door sealing
- All hardware of corrosion resistant material



Model: FPS Series



Model: FKS Series



Model: FKC Series



Model: FSL Series

► Standard Features

- Higher fire rating (Certified to BS476 Part 7 Class 1/UL94 V-0)
- Insulated construction sandwich with PU foam/Rockwool.
- Anti-vandal construction sandwich with WBP plywood.
- Stainless steel hardware
- External colors in any other RAL color.

Model: FPS series (Kiosk for Package Sub-station)

- Naturally ventilated with double leaf door in front & rear
- Wall thickness 6 mm commonly and 10mm at stress points
- Anodized aluminum louvers with backup insect mesh
- Heavy duty butt hinges of stainless steel
- Heavy duty handle locking
- Wind stays on each door
- Lifting hooks
- All hardware of galvanized steel or corrosion resistant material
- Customizable with different accessories & dimensions



All dimensions are in mm

S.No.	Model Number	External Size		
		h	w	d
1	FPS250350210	2500	3500	2100
2	FPS250400260	2500	4000	2600
3	FPS250450310	2500	4500	3100
4	FPS300400260	3000	4000	2600
5	FPS300500310	3000	5000	3100
6	FPS300550560	3000	5500	5600

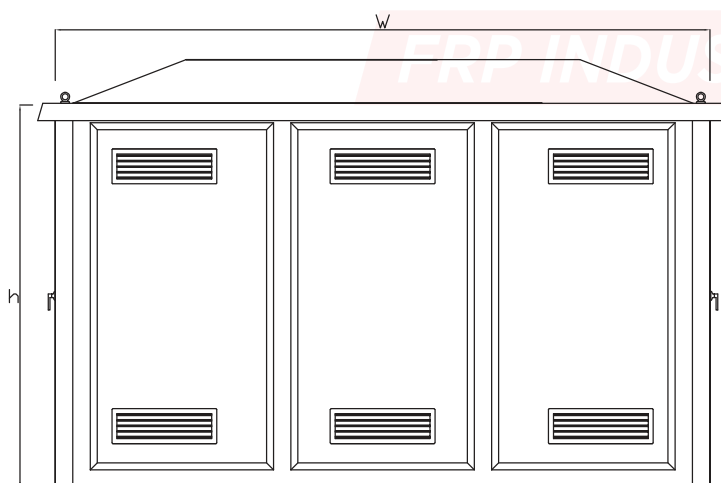

SIDE ELEVATION

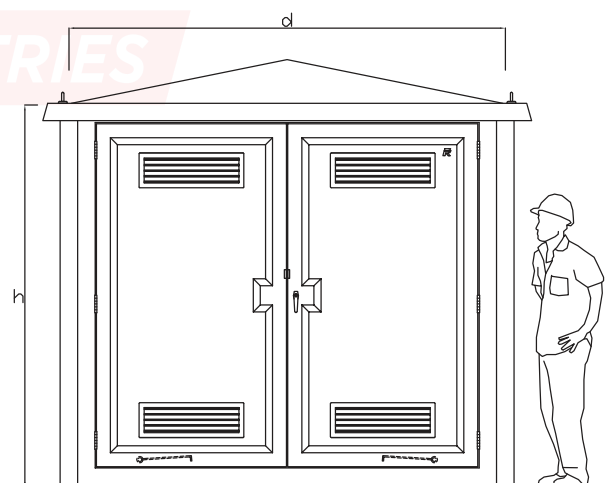

FRONT/REAR ELEVATION

Model: FKS Series (IP55 Kiosk)

- Double leaf door in front.
- Ingress protection to IP55
- Wall thickness 6 mm commonly and 10mm at stress points.
- Insulated construction with polyurethane foam encapsulated with FRP
- Heavy duty butt hinges of stainless steel
- Heavy duty three-point handle locking
- Wind stays on each door
- Lifting hooks
- Provisions for inner lightings and door operated limit switch
- Provisions to install AC unit, JB, FACP, anti-condensation heaters, fire extinguisher, smoke detector and other components
- All hardware of stainless steel
- Customizable with different accessories & dimensions



Options

- Higher wall thickness
- Single skin construction
- Anti-vandal construction with WBP plywood encapsulated with FRP
- Higher fire rating
- Emergency exit door
- Access to auxiliary power supply

All dimensions are in mm

S.No.	Model Number	External Size		
		h	w	d
1	FKS200100110	2000	1000	1100
2	FKS200200110	2000	2000	1100
3	FKS250100110	2500	1000	1100
4	FKS250200160	2500	2000	1600
5	FKS250400210	2500	4000	2100
6	FKS300500310	3000	5000	3100
7	FKS300600410	3000	6000	4100

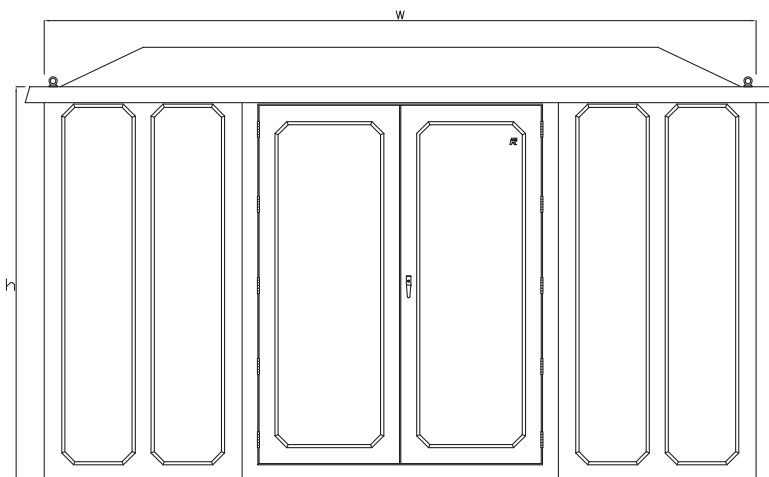

FRONT ELEVATION

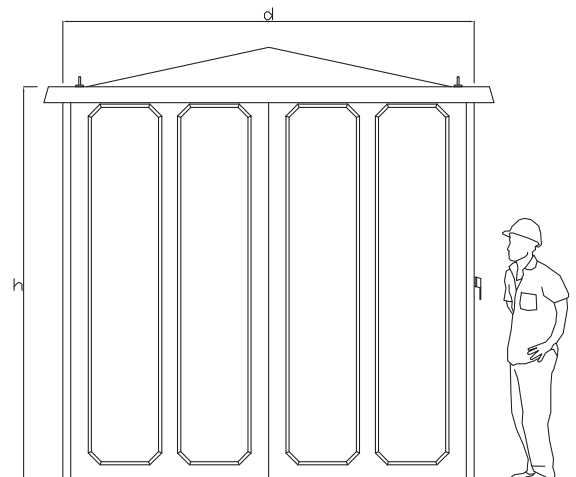

SIDE ELEVATION

Model: FKC Series (Kiosk For Capacitor Banks)

- Naturally ventilated with single leaf door in front
- Wall thickness 6 mm commonly and 10mm at stress points
- Anodized aluminum louvers with backup insect mesh
- Heavy duty butt hinges of stainless steel
- Heavy duty handle locking
- Wind stays on each door
- Lifting hooks
- All hardware of non-magnetic material or stainless steel
- Customizable with different accessories & dimensions



Options

- Higher wall thickness
- Insulated construction with PU Foam encapsulated with FRP
- Anti-vandal construction with WBP plywood encapsulated with FRP
- Higher fire rating

All dimensions are in mm

S.No.	Model Number	External Size		
		h	w	d
1	FKC300400225	3000	4000	2250
2	FKC350465225	3500	4650	2250
3	FKC365635225	3650	6350	2250
4	FKC410465225	4100	4650	2250
5	FKC450220220	4500	2200	2200

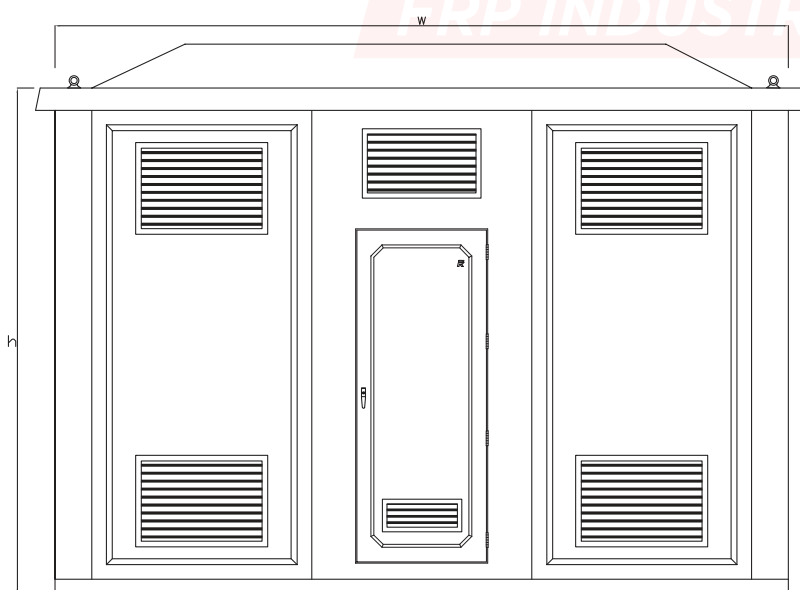

FRONT ELEVATION

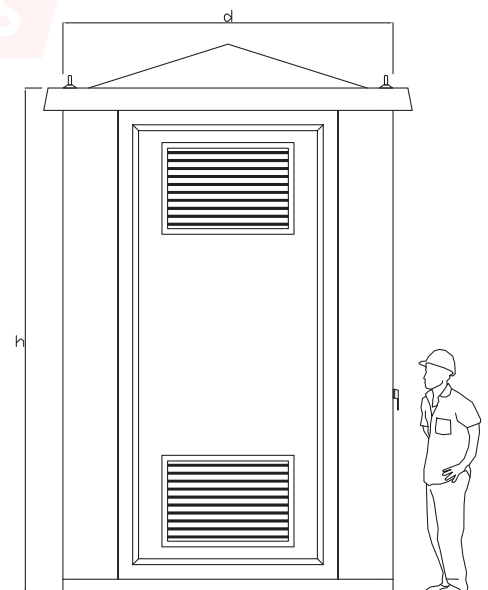

SIDE ELEVATION

Model: FSL Series (Shelters)

- Single leaf self-locking access door with safety glass & anti-panic bar
- Ingress protection to IP55
- Wall thickness 6 mm commonly and 10mm at stress points.
- Insulated construction with polyurethane foam encapsulated with FRP
- Heavy duty FRP or metal flooring.
- Heavy duty butt hinges of stainless steel
- Provisions for inner lightings and door operated limit switch
- Provisions to install AC unit, JB, FACP, anti-condensation heaters, fire extinguisher, smoke detector and other components
- All hardware of stainless steel
- Customizable with different accessories & dimensions



► Options

- Higher wall thickness
- Anti-vandal construction with WBP plywood encapsulated with FRP
- Higher fire rating
- Air lock chamber
- Additional sunshade

All dimensions are in mm

S.No.	Model Number	External Size		
		h	w	d
1	FSL250200160	2500	2000	1600
2	FSL250400210	2500	4000	2100
3	FSL300500310	3000	5000	3100
4	FSL300600410	3000	6000	4100

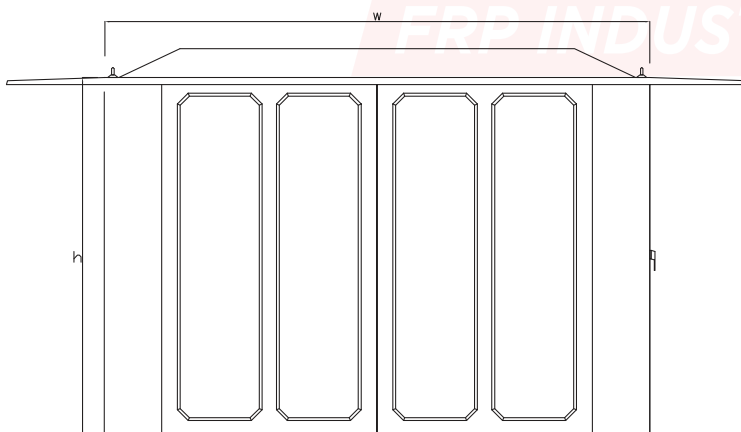

SIDE ELEVATION

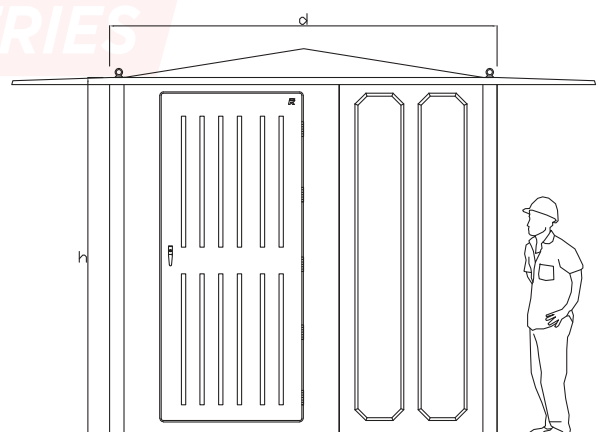

FRONT ELEVATION

Disclaimer: FRP Industries reserves the right to amend the design shown in this document without prior notice

FRP instrument sunshades are designed to protect instruments and its LED/LCD display from the direct rays of sun. Additionally, provide curtailed shield from dust build up, rain and falling matters. These sunshades are weatherproof, UV resistant, corrosion resistant and suitable for outdoor use in harsh weather conditions of high humidity & temperature dominant in gulf region. FRP sunshades are non-absorbent to hydrocarbons, made by "amine free" polyester resin and have superior thermal insulation. These instrument sunshades have design life in excess of 40 years.

FRP instrument sunshades supplied with standard mounting accessories- back plate and U-bolt/clamp set to suit 2" pipe mounting in stainless steel grade SS316. Options of other bespoke mounting accessories can be supplied to suit a specific instrument installation.

FRP instrument sunshades have following choices:

- Single Instrument Sunshades
- Multiple Instrument Sunshades

► Standard Features

- Weatherproof and UV resistant (Certified to ASTM G154)
- Fire retardant & self-extinguishing (Certified to BS476 Part 7 Class 2)
- Impact resistant up to IK10 (Certified to BS EN 62262)
- Anti-static (Certified to IEC 60079-0)
- Wall thickness 4mm
- Standard external finish: Semi-gloss UV resistant grey color gelcoat finish to RAL 7035.
- All hardware of stainless steel.

► Options

- Higher fire rating (Certified to BS476 Part 7 Class 1/UL94 V-0)
- Higher wall thickness.
- External colors in any other RAL color.



FRP Instrument Sunshades

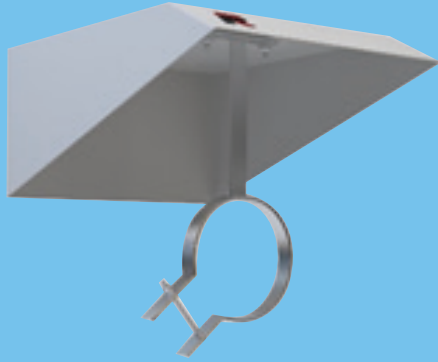

Bespoke Mounting-Type I

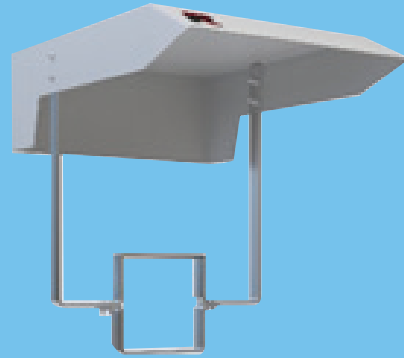

Bespoke Mounting-Type II

All dimensions are in mm

S.No.	Model Number	External Size			No. of Clamp
		w	d	h	
1	FIS210365100	210	365	100	1
2	FIS230300180	230	300	180	1
3	FIS250300120	250	300	120	1
4	FIS300300150	300	300	150	1
5	FIS330250140	330	250	140	1
6	FIS350350300	350	350	300	2
7	FIS360420370	360	420	370	2
8	FIS400400270	400	400	270	2
9	FIS400450330	400	450	330	2
10	FIS820420370	820	420	370	2

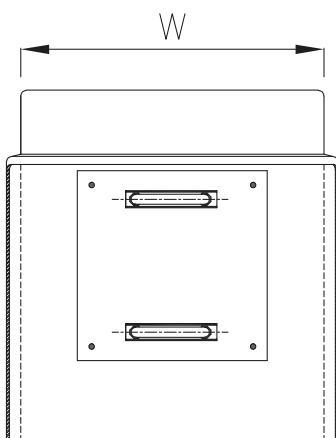

FRONT ELEVATION

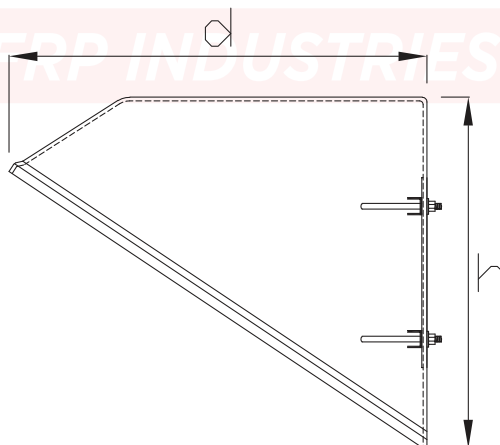

SECTIONAL ELEVATION

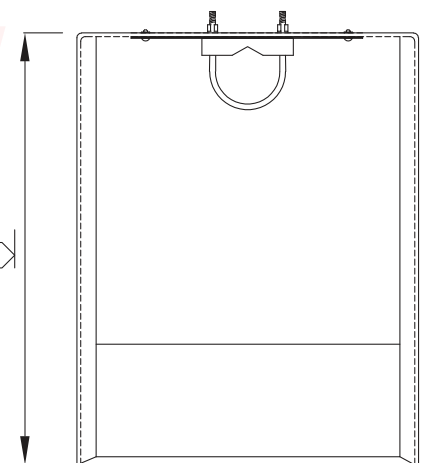

SECTIONAL PLAN

Disclaimer: FRP Industries reserves the right to amend the design shown in this document without prior notice

FRP Instrument Protection-CrossBox

FRP instrument protection CrossBox are designed to protect instruments from all kind of weather in outdoor installation. These CrossBox are weatherproof, IP rated, UV resistant, corrosion resistant, non-absorbent to hydrocarbons and suitable for outdoor use in harsh weather conditions of high humidity & temperature dominant in gulf region. FRP CrossBox designed with two-part construction, split diagonally, lower part for installation of equipment and easy access, upper part as lid with UV resistant viewing window, stackable design for space saving storage and transport. These instrument protection CrossBox have design life in excess of 40 years.

► Features

- Ingress protection to IP65/ NEMA 4X & lesser (Certified to BS EN 60529/ NEMA250)
- Weatherproof and UV resistant (Certified to ASTM G154)
- Fire retardant & self-extinguishing (Certified to BS476 Part 7 Class 2)
- High impact resistant up to IK10 (Certified to BS EN 62262)
- Anti-static (Certified to IEC 60079-0)
- Wall thickness 4mm
- Standard external finish: Semi-gloss UV resistant grey color gelcoat finish to RAL 7035
- High temperature resistant & long-life EPDM rubber gasket for lid sealing
- All hardware of stainless steel
- Installation option- Vertical or Horizontal
- Customizable with different specification, accessories & dimensions

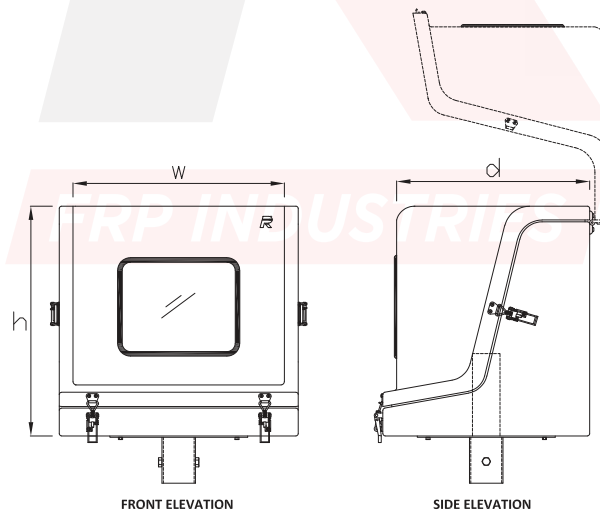
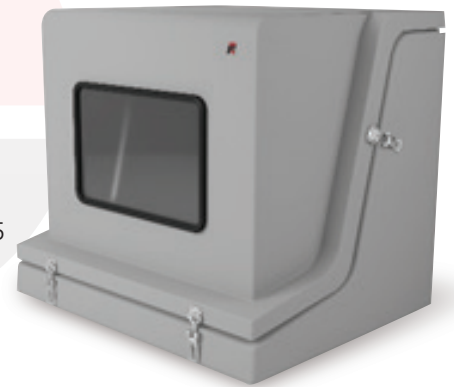

All dimensions are in mm

S.No.	Model Number	External Size		
		h	w	d
1	FXB050046042	500	460	420
2	FXB050070042	500	700	420
3	FXB050090042	500	900	420

Disclaimer: FRP Industries reserves the right to amend the design shown in this document without prior notice

Material Data Sheet

Tensile Strength	85 N/mm ²	ISO 527-1:2019
Flexural Strength	130 N/mm ²	BS 2782-10:1977
Tensile Modulus	8 kN/mm ²	ISO 527-1:2019
Flexural Modulus	7 kN/mm ²	BS 2782-10:1977
Impact Strength	45 kJ/mm ²	ISO 180-1993
Hardness (Barcol)	40	ASTM D2583:1987
Tensile Elongation	1.8%	ISO 527:2019
Oxygen Index (approx.)	25%	ISO 4589:1996
Heat Transfer Coefficient	5.7 W/m ² K	
Thermal Expansion Coefficient	24 x 10 ⁻⁶ m/°C	
Operating Temperature	-20°C to +85°C	
Exterior Finish	UV resistant, semi gloss gelcoat coloured finish	
Internal Finish	Reasonably smooth flowcoat coloured finish	

Project Supply References

S.N.	Project	EPC/Client
1	Al Zour LNG Import Terminal Project in Kuwait	Hyundai E&C/ Kuwait National Petroleum Company (KNPC)
2	Basrah Gas NGL Plant Project, Iraq	Wood PLC/ Basrah Gas Company
3	South East Tie Onshore Oil Field Development (Packages C)	Petrofac International/ ADNOC Onshore
4	Salalah Project	Ministry of Defence Engineering Services (MODES) , Oman
5	Bab Integrated Facility Project	China National Petroleum Company (CNPC)/ ADNOC Onshore
6	EPC Projects in Das Island	Tamimi Group/ ADNOC Offshore
7	Maintenance Project	Petroleum Development Oman (PDO) , Oman
8	DEWA Power & Desalination Plant, K-Station	DECO/ Dubai Electricity & Water Authority (DEWA)
9	Zirku Facilities Capacity Enhancement (Train5)	CCEL-CCC Consortium/ ADNOC Offshore
10	Wudam Naval Base Project	Ministry Of Defense (MOD) , Oman
11	Waad Al Shamal City Development by BECHTEL, KSA	ASG Contracting
12	Refinery Project, Sohar	Bhawan Group/ Oman Oil Refineries & Petroleum Industries , Oman